

LRV 400

SUPACAT

DEVELOPERS OF HIGH MOBILITY VEHICLES



The Light Reconnaissance Vehicle 400 (LRV 400) is an exciting new addition to the Supacat range of high performance off-road military vehicles. Supacat have partnered with the race vehicle designers, Qt Services, to develop the LRV and market it into the defence sector. Supacat are able to offer this vehicle as a fully integrated military variant including the entire spectrum of Integrated Logistic Support products and services.

Using the renowned Qt Wildcat race vehicle as a start point, Supacat has combined Qt Services' world-wide pedigree in rally raid competition with Supacat's well-known military vehicle prowess, offering unrivalled performance for a vehicle in this size and weight class.

'High speed through harsh environments' is the LRV's strength, offering the user an ideal lightweight rapid intervention vehicle for special forces, border patrol, reconnaissance or strike forces. The race proven design incorporates a tubular space-frame chassis with state of the art suspension providing superb performance, reliability and safety. The LRV's size and weight enables effective air portability, including tactical CH-47 internal loading. Whilst primarily fulfilling light force reconnaissance and strike concepts of operation, low-weight armour solutions can also be fitted as an option. A variety of communications and weapons systems can also be integrated depending on the customer's requirements.

A Length	4300 mm
B Width	1800 mm
C Height	1800 mm
D Track	1640 mm
E Wheelbase to Axle 2	3200 mm
F Front Overhang	600 mm
G Rear Overhang	570 mm
H Ground Clearance	Min 300 mm Max 500mm
I Approach Angle	60°
J Departure Angle	68°
K Ramp Over Angle	150°

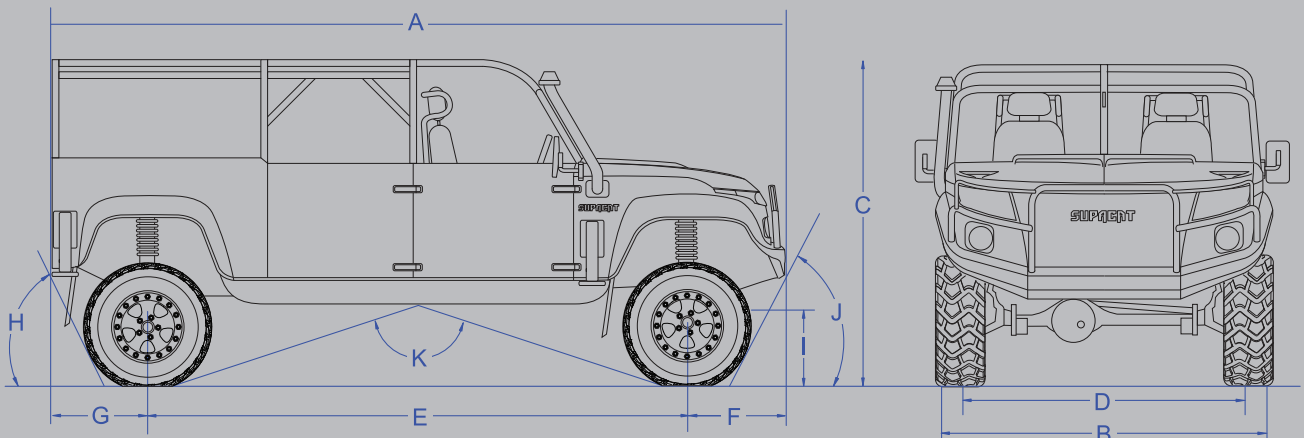

LRV 400

SUPACAT

DEVELOPERS OF HIGH MOBILITY VEHICLES

Weight (GVW)	3500 kg
Payload	1400 kg
Kerb weight	2100 kg
Turning circle	(wall to wall)13.2 m
Speed	170 km/h
Fuel capacity	160 Litres
Maximum road range	1000 km
Fording	1000 mm
Gradient	45°
Side slope	40°

Engine

Ford 5 cyl 3.2lt militarised turbo diesel	Power 236 hp Torque 550 Nm
V8 petrol engine options	Power 430hp - 640hp

Transmission

Automatic and manual gearbox options.
Hi and Low range 2WD and 4WD with centre diff lock.

Differentials

Front and rear air locking.

Suspension and axles

Beam axles and 300 mm travel race derived hydraulic shock absorbers.
Coil over multi rate dampers adjustable for bump and rebound.
Hydraulic bump stops.

Steering

Power assisted

Brakes

Ventilated disc all round. 4 piston calliper option, 320 mm Rotor option.

Tyres

265/75 R16 (265/75 R18 optional)

Electrical system

24 V DC

Options

Hutchinson bead-lock run flats, self recovery winch, remote weapons station, weapon mounts, smoke grenade launchers, IR lights, ballistic armour and ballistic crew seats, RHD or LHD, on board water boiler, Pinnacle compass, canvas roof and side screens, forward and rear facing IR cameras, payload indicator, detachable polycarbonate windscreen, self levelling hydraulic stability platform and jacking system, 12V and 24V electrics, dry-break quick change main radiator system, Nato tow hook, motorsport spec brakes, LED hi-mount T16 driving lights, LED hi-mount rear work lights.

