



Supacat have partnered with the vehicle designers, QT Services, to market the Wildcat in defence markets. Supacat are able to offer this vehicle as a fully integrated military variant including the entire spectrum of Integrated Logistic Support products and services.

The Wildcat is an exciting new addition to the Supacat range of high performance off-road military vehicles. With a fully proven world-wide pedigree in Rally Raid competition, the Wildcat can offer unrivalled performance for a vehicle in this size and weight class.

'High speed through harsh environments' is the Wildcat's strength, offering the user an ideal rapid intervention vehicle for special forces, border patrol, reconnaissance or strike forces.

The race proven design incorporates a tubular space-frame chassis with state of the art suspension providing superb performance, reliability and safety.

The Wildcat's size and weight enables effective air portability and whilst primarily fulfilling a light strike concept of operations, lightweight armour solutions can also be fitted as an option. A variety of communications and weapons systems can also be integrated depending on the customer's requirements.

A Length	3800 mm
B Width	1755 mm
C Height	1790 mm
D Track	1640 mm
E Wheelbase to Axle 2	2700 mm
F Front Overhang	460 mm
G Rear Overhang	570 mm
H Ground Clearance	Min 340 mm Max 500mm
I Approach Angle	70°
J Departure Angle	68°
K Ramp Over Angle	142°

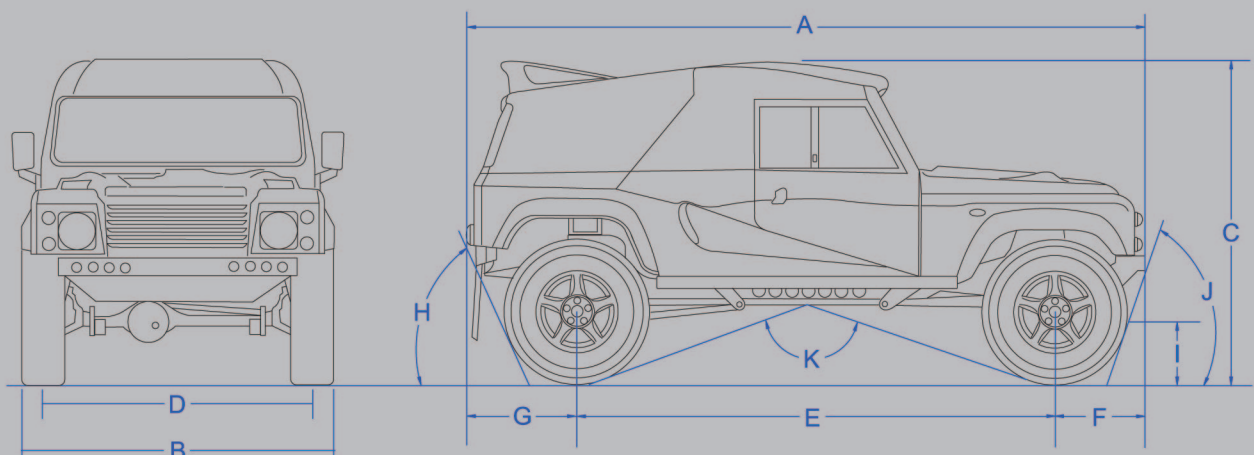



Weight (GVW)	2580 kg
Payload	900 kg
Kerb weight	1680 kg
Turning circle	(wall to wall) 13.2 m
Speed	170 km/h
Fuel capacity	365 Litres
Maximum road range	2970 km
Fording	600 mm
Gradient	45°
Side slope	40°
Engine	
2.8L TGV Diesel	Power 160 hp Torque 400 Nm
Land Rover 3L V6 Diesel	Power 315 hp Torque 700 Nm
Land Rover 4L V8 Petrol	Power 270 hp

Transmission

Automatic and Manual Gearbox options.
Hi and Low Range 2WD and 4WD with centre diff lock.

Differentials

Air Locking

Suspension and axles

Beam axle with hydraulic shock absorbers with 300 mm of travel.
Multi rate dampers adjustable for bump and rebound. Coil over option.

Steering

Power assisted

Brakes

Ventilated disc all round. 4 piston calliper option, 320 mm Rotor option.

Tyres

235/85 R16

Electrical system

24 V DC

Options

Runflats, self recovery winch, remote weapons station, weapon mounts, smoke grenade launchers, IR lights, ballistic armour and ballistic crew seats, RHD or LHD.

WILDCAT



Photographs courtesy Gary Stuart