

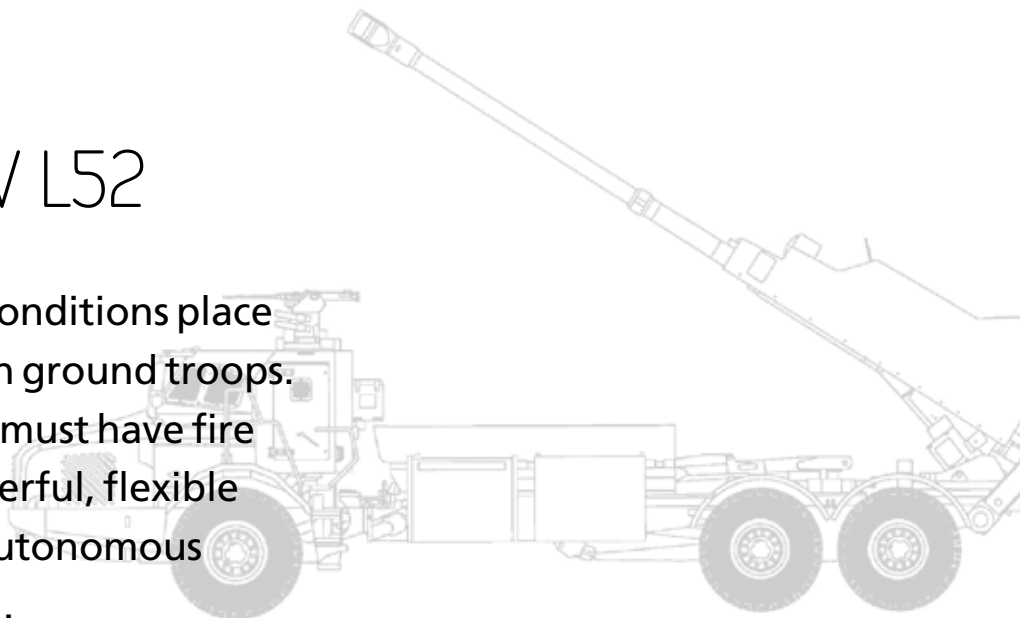

Archer

155MM FH 77 BW L52

Today's testing battlefield conditions place unprecedented demands on ground troops. To operate effectively, they must have fire support assets that are powerful, flexible and feature high levels of autonomous operation under protection.



Archer is a self-propelled field howitzer that can operate auto-nomously in tandem with today's command and control systems. The 155 mm, 52 calibre, long-range weapon features an outstanding tracking capability and an intensive rate of fire, engaging ground and sea targets, both stationary and moving, with high precision.

The projectile magazines handle all types of 155 mm artillery ammo, including advanced sensor-fused and

precision-guided munitions. Depending on customer requirements, the charge magazine can be adapted for either conventional bags or modular systems. Fire capabilities include direct fire and Multiple Rounds Simultaneous Impact (MRSI).

Precision targeting is achieved using highly integrated components, such as ballistic calculation, in the gun computer system. Firing and operation of the gun computer can both be handled automatically or manually, providing ultimate flexibility.



Together with an extensive ammunition portfolio, Archer can operate independently on widely dispersed battlefields, providing continuous fire support against a huge variety of threats.

Power under pressure

Today's testing battlefield conditions place unprecedented demands on ground troops. To operate effectively, they must have fire support assets that are powerful, flexible and feature high levels of autonomous operation under protection.



PROTECTION

The crew cabin is protected against NBC threats, artillery fragmentation, mine attack and blast overpressure. Significant separation of the crew from the armament and munitions further enhances survivability.

The system also features a Remotely-Controlled Weapon Station (RCWS) mounted on top of the crew compartment.

MOBILITY

Archer is mounted on a commercial articulated vehicle specially developed for high mobility in the most difficult terrain. It provides an average road speed of 70 km/h with a manoeuvre range of 1,000 km per day. The system is supported by an Ammunition Resupply Vehicle (ARV), designed to provide a complete reload of the howitzer within minutes.



Technical Data

Dimensions

- Width: 3.0 m
 - Height: 3.4 m
 - With RCWS: 4.0 m
 - Max. elevation: 10.4 m
 - Length: 14.3 m
 - Weight: 33 tonnes (approx.)
-

Firing

- Calibre: 155 mm
 - Barrel length: 52 calibre
 - Elevation: -1° to +70°
 - Traverse: -85° to +85°
 - Projectile magazine: 21 rounds
 - Charge magazine: 18 charges
 - Rate of fire (burst): 3 rounds/20 sec
 - Rate of fire (intensive): 21 rounds/3.5 min
 - Rate of fire (continuous): 54 rounds/35 min
 - Range: HEER 40: Up to 40 km
 - BONUS: Up to 35 km
 - EXCALIBUR: Up to 50 km
 - Into action: approx. 20 secs
 - Out of action: approx. 20 secs
 - MRSI: Up to 6 rounds
 - Direct fire: Day and night capability
 - Secondary armament: Grenade launcher or heavy machine gun (optional)
-

Mobility

- Drive: 6x6
 - Road speed: 70 km/h
 - Cruising range: 500 km
 - Fuel tank: 400 litres
 - Max. longitudinal slope: 30°
 - Max. lateral slope traverse: 28°
 - Fording: 1 m
 - Ground clearance: 0.4 m
 - Engine output: 252 kW
-

Crew

- Crew members: 3 (4)
 - Ballistic protection: Fragment
 - Bullet
 - AT mine
 - CBRN protection: Overpressure principle
 - Climate control system: For harsh winter and summer conditions
-

BAE Systems, Inc.
Platforms & Services
www.baesystems.com

For more information contact
platforms.services@baesystems.com

Disclaimer and copyright

This document gives only a general description of products and services and except where expressly provided otherwise shall not form part of any contract. From time to time, changes may be made in the products or conditions of supply.

© 2016 BAE SYSTEMS. All rights reserved.

The information contained in this document is proprietary to BAE SYSTEMS unless stated otherwise and is made available in confidence; it must not be used or disclosed without the express written permission of BAE SYSTEMS. This document may not be copied in whole or in part in any form without the express written consent of BAE SYSTEMS which may be given by contract.

BAE SYSTEMS is a registered trade mark of BAE Systems plc.

05.16.ARCHER.BTR

Approved for public release 12.02.