



HMT 600

High Mobility Transporter

SPECIFICATION SHEET



Named the 'Coyote' by our UK customer, the HMT 600 series pushes the mobility levels of support type platforms to another level.

Using the HMT variable height air suspension system, the 600 will match the 400's impressive cross-country performance yet provides a significant increase in payload.

As with its smaller 400 series sister, the 600 can be supplied with an optional mine blast and ballistic protection kit and can be fitted with a variety of mission specific hampers, weapons, communications, ISTAR and force protection equipment to suit a wide range of operational roles.

A	Length	7040 mm
B	Width	2050 mm
C	Height	Min 1885 mm Max 2445 mm
D	Track	1700 mm
E	Wheelbase to Axle 2	3000 mm
F	Wheelbase to Axle 3	4250 mm
G	Front Overhang	1300 mm
H	Rear Overhang	1490 mm
I	Ground Clearance	Min 180 mm Max 485 mm
J	Approach Angle	40°
K	Departure Angle	40°
L	Ramp Over Angle	150°

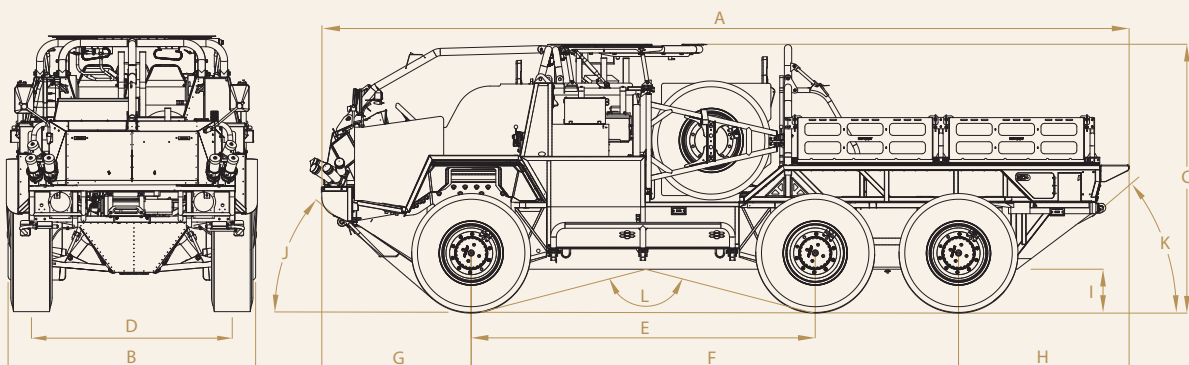

HMT 600 Vehicle Specification

Weight (GVW)	10500 kg
Payload	3900 kg
Kerb weight (with fuel and armour)	6600 kg
Turning circle (kerb to kerb)	17.5 m
Speed	120 km/h
Fuel capacity	200 Litres
Maximum road range	700 km
Fording	1000 mm
Gradient	60%
Side slope	35°
Engine	Cummins 6.7L, 6 cylinder Diesel, 180hp, 700Nm torque
Transmission	5 speed automatic
Drive	2WD/4WD, High low range
Brakes	Air over hydraulic system, ABS
Differentials	Limited slip
Steering	Power assisted
Tyres	335/80 R20
Electrical system	24v DC
Suspension	Independent with air adjustable ride height
Protection	Mine blast and ballistic protection
Options	

Runflat tyres, locking differentials, self recovery winch, weapon mounts, remote weapons station, smoke grenade launchers, IR lights, RHD or LHD.

